



Guidance on regulations
for the
**Transport of Infectious
Substances 2015–2016**

Applicable as from 1 January 2015

Global Capacities
Alert and Response



**World Health
Organization**

© World Health Organization 2014

All rights reserved. Publications of the World Health Organization are available on the WHO web site (www.who.int) or can be purchased from WHO Press, World Health Organization, 20 Avenue Appia, 1211 Geneva 27, Switzerland (tel.: +41 22 791 3264; fax: +41 22 791 4857; email: bookorders@who.int).

Requests for permission to reproduce or translate WHO publications – whether for sale or for non-commercial distribution – should be addressed to WHO Press through the WHO web site (www.who.int/about/licensing/copyright_form/en/index.html).

The designations employed and the presentation of the material in this publication do not imply the expression of any opinion whatsoever on the part of the World Health Organization concerning the legal status of any country, territory, city or area or of its authorities, or concerning the delimitation of its frontiers or boundaries. Dotted lines on maps represent approximate border lines for which there may not yet be full agreement.

The mention of specific companies or of certain manufacturers' products does not imply that they are endorsed or recommended by the World Health Organization in preference to others of a similar nature that are not mentioned. Errors and omissions excepted, the names of proprietary products are distinguished by initial capital letters.

All reasonable precautions have been taken by WHO to verify the information contained in this publication. However, the published material is being distributed without warranty of any kind, either express or implied. The responsibility for the interpretation and use of the material lies with the reader. In no event shall the World Health Organization be liable for damages arising from its use.

Acknowledgement

The extracts from the Recommendations on the *Transport of Dangerous Goods, Model Regulations*, 18th revised edition, New York and Geneva, United Nations, 2013 are reproduced by kind permission of the United Nations.

Note to the reader:

This document replaces the *WHO Guidance on regulations for the transport of infectious substances 2013-2014*.

For the reader's ease, updated text is highlighted as follows:

- ❖ modified text

Contents

Contents

Acknowledgement	ii
Contents.....	1
Introduction	3
International regulations	4
National regulations	4
Definitions	5
Infectious substances.....	5
Cultures	5
Patient specimens.....	5
Biological products	5
Medical or clinical wastes	5
Classification.....	6
Category A	6
Category B	6
Exemptions	6
Biological products	8
Genetically modified microorganisms and organisms	8
Medical or clinical wastes	8
Infected animals	9
General preparation of shipments for transport	9
Basic triple packaging system	9
Packaging, labelling and documentation requirements for infectious substances in Category A.....	10
Packaging	10
Marking	12
Labelling	12
Documentation	14
Packaging, labelling and documentation requirements for infectious substances in Category B.....	16
Packaging	16
Marking	17
Documentation	17
Overpacks.....	18
Reusing packaging materials	18
Shipping empty packagings.....	18
Refrigerants	18
Training	19
Recommendations for countries that have not adopted the United Nations system	20
Transport planning	20
The shipper (sender, consignor)	20
The carrier	20
The receiver (consignee)	21
Requirements for air mail	21
Spill clean-up procedure.....	21
Incident reporting	22
Annex 1 Additional information on the United Nations System for the Transport of Dangerous Goods	23

Annex 2 Examples of infectious substances included in Category A24
Annex 3 Packing Instruction P62026
Annex 4 Packing Instruction P65028
Annex 5 List of dangerous goods related to the transport of infectious substances32
Annex 7 Flowchart for the classification of infectious substances and patient specimens35

Introduction

Infectious substances are transported for a variety of different reasons, within countries and across international borders. It is incumbent upon shippers to ensure packaging and shipping conditions meet regulatory requirements to preserve the integrity of materials, and facilitate their timely arrival at destination.

Postal, airline and other transport industry personnel may have concerns about the possibility of becoming infected as the result of exposure to infectious microorganisms that may escape from broken, leaking or improperly packaged material. The packaging of infectious substances for transport must therefore be designed to minimize the potential for damage during transport. In addition, the packaging must ensure the integrity of the materials and so, in turn, timely and accurate processing of specimens.

The following guidelines provide information for classifying infectious substances for transportation and ensuring their safe packaging. They stress the importance of developing a working relationship between those involved – the sender, the carrier and the receiver – in order to provide for safe and expeditious transport of these materials.

- ❖ These guidelines provide practical guidance to facilitate compliance with applicable international regulations for the transport of infectious substances and patient specimens by all modes of transport, both nationally and internationally, and include the changes that apply from 1 January 2015. They replace the guidelines issued by the World Health Organization (WHO) in 2013 (document WHO/CDS/IHR/2012.12). This publication, however, does not replace national and international transport regulations.

Today, thousands of samples of infectious substances need to be shipped and are shipped daily around the world. Human and animal specimens are collected and shipped for a variety of reasons, including disease investigations, clinical trials, surveillance studies, antidoping testing, routine analyses, etc. Regular and occasional shippers consign infectious substances for transport on a daily basis. These include the pharmaceutical industry, health care facilities, diagnostic and research laboratories, medical practitioners, and individual patients.

In the interest of global public health, human and animal specimens need to be transported safely, timely, efficiently and legally from the place where they are collected to the place where they will be analyzed. Regardless of the presumed infection status of the patient, specimens of human and animal origin should be packaged and transported in such a way as to protect those engaged in transportation from the risk of infection. Risks of infection of personnel involved in transport may not be fully eliminated. However, they can undoubtedly be kept to a minimum. In addition, damage to packaging also means that samples dispatched for urgent tasks like analyses are unlikely to arrive to destination on time.

In order to make appropriate decisions, shippers must understand their need and obligation to be familiar with regulatory requirements. Dangerous goods regulations require all personnel involved in transport to undergo appropriate training. Appropriate training and education, commensurate with the shipper's responsibilities, will provide the shipper with the necessary degree of familiarity with applicable requirements, addressing identification, classification, packaging, marking, labelling, refrigeration and required documentation for the transport of infectious substances.

This document will familiarize the reader with current international and modal requirements for the shipment of infectious substances.

International regulations

The international regulations for the transport of infectious substances by any mode of transport are based upon the Recommendations made by the Committee of Experts on the Transport of Dangerous Goods (UNCETDG), a committee of the United Nations Economic and Social Council. The Recommendations are presented in the form of Model Regulations. The United Nations Model Regulations are reflected in international law through international modal agreements (links to further information are provided in Annex 1):

- Air** The *Technical Instructions for the Safe Transport of Dangerous Goods by Air* published by the International Civil Aviation Organization (ICAO) are the legally binding international regulations. The International Air Transport Association (IATA) publishes Dangerous Goods Regulations (DGR) that incorporate the ICAO provisions and may add further restrictions (where necessary such restrictions are included in these guidelines). The ICAO rules apply on all international flights. For national flights, i.e. flights within one country, national civil aviation authorities apply national legislation. This is normally based on the ICAO provisions, but may incorporate variations. State and operator variations are published in the ICAO Technical Instructions and in the IATA Dangerous Goods Regulations.
- Rail** Regulations concerning the *International Carriage of Dangerous Goods by Rail* (RID) apply to countries in Europe, the Middle East and North Africa. RID also applies to domestic transport in the European Union through Council Directive 2008/68/EC.
- ❖ **Road** The *European Agreement concerning the International Carriage of Dangerous Goods by Road* (ADR) applies to 48 countries. In addition, modified versions of the convention are being used by countries in South America and South-East Asia. ADR also applies to domestic transport in the European Union through Council Directive 2008/68/EC.
- Sea** The *International Maritime Dangerous Goods Code* published by the International Maritime Organization (IMO) is of mandatory application for all contracting parties to the International Convention for the Safety of Life at Sea (SOLAS).
- Post** The *Letter post manual* published by the Universal Postal Union (UPU) reflects the United Nations Recommendations using the ICAO provisions as the basis for shipments.

The World Health Organization serves in an advisory capacity to UNCETDG and ICAO.

National regulations

Many countries adopt the United Nations Model Regulations in their entirety to stand as their national dangerous goods legislation. Some countries apply variations. National authorities should provide details of their own national requirements.

- ❖ **Note:** These guidelines are based on the 18th revised edition of the United Nations Recommendations on the Transport of Dangerous Goods, the text of which is reflected in the 2015 editions of the international modal regulations (e.g. ICAO Technical Instructions for the Safe Transport of Dangerous Goods by Air, Doc 9284 AN/905, 2015–2016 Edition; ADR, European Agreement Concerning the International Carriage of Dangerous Goods by Road, applicable as from 1 January 2015) and in many sets of national legislation. In December 2014, UNCETDG agreed on further changes for the 19th edition. These changes do not come into force until 2017. If, in the future, further modifications are made to the section of the United Nations Recommendations that deals with infectious substances and patient specimens, the WHO guidelines will be updated accordingly.

Definitions

In describing transport safety measures, the terms “infectious substances” and “infectious materials” are considered to be synonymous. The term “infectious substances” is used in this document. Text reproduced from the United Nations Model Regulations is italicized.

Infectious substances

For the purposes of transport, infectious substances are defined as substances which are known or are reasonably expected to contain pathogens. Pathogens are defined as microorganisms (including bacteria, viruses, rickettsiae, parasites, fungi) and other agents such as prions, which can cause disease in humans or animals. The definition is applied to all specimens except those explicitly exempted (see below).

Cultures

Cultures are the result of a process by which pathogens are intentionally propagated. This definition does not include human or animal patient specimens as defined below.

Patient specimens

Patient specimens are human or animal materials, collected directly from humans or animals, including, but not limited to, excreta, secreta, blood and its components, tissue and tissue fluid swabs, and body parts being transported for purposes such as research, diagnosis, investigational activities, disease treatment and prevention.

Biological products

Biological products are those products derived from living organisms which are manufactured and distributed in accordance with the requirements of appropriate national authorities, which may have special licensing requirements, and are used either for prevention, treatment, or diagnosis of disease in humans or animals, or for development, experimental or investigational purposes related thereto. They include, but are not limited to, finished or unfinished products such as vaccines.

Genetically modified microorganisms (GMMOs) and organisms (GMOs) *Genetically modified microorganisms not meeting the definition of infectious substance are classified in Class 9 (Miscellaneous dangerous substances and articles, including environmentally hazardous substances). GMMOs and GMOs are not subject to dangerous goods regulations when authorized for use by the competent authorities of the countries of origin, transit and destination. Genetically modified live animals shall be transported under terms and conditions of the competent authorities of the countries of origin and destination.*

Medical or clinical wastes

Medical or clinical wastes are wastes derived from the medical treatment of animals or humans or from bio-research.

Classification

Dangerous goods are assigned UN numbers and proper shipping names according to their hazard classification and their composition. Proper shipping names are used to clearly identify the dangerous article or substance.

Infectious substances are classified in Division 6.2 and assigned to UN 2814, UN 2900, UN 3291 or UN 3373, as appropriate.

Infectious substances are divided into the following categories:

Category A

An infectious substance which is transported in a form that, when exposure to it occurs, is capable of causing permanent disability, life-threatening or fatal disease in otherwise healthy humans or animals. Indicative examples of substances that meet these criteria are given in the table in Annex 2.

NOTE: *An exposure occurs when an infectious substance is released outside of the protective packaging, resulting in physical contact with humans or animals.*

- (a) *Infectious substances meeting these criteria which cause disease in humans or both in humans and animals shall be assigned to United Nations number UN 2814. Infectious substances which cause disease only in animals shall be assigned to UN 2900.*
- (b) *Assignment to UN 2814 or UN 2900 shall be based on the known medical history and symptoms of the source human or animal, endemic local conditions, or professional judgement concerning individual circumstances of the source human or animal.*

NOTE 1: *The proper shipping name for UN 2814 is INFECTIOUS SUBSTANCE, AFFECTING HUMANS. The proper shipping name for UN 2900 is INFECTIOUS SUBSTANCE, AFFECTING ANIMALS only.*

NOTE 2: *The table in Annex 2 is not exhaustive. Infectious substances, including new or emerging pathogens, which do not appear in the table but which meet the same criteria shall be assigned to Category A. In addition, if there is doubt as to whether or not a substance meets the criteria it shall be included in Category A.*

NOTE 3: *In the table in Annex 2, the microorganisms written in italics are bacteria, mycoplasmas, rickettsiae or fungi.*

Category B

An infectious substance which does not meet the criteria for inclusion in Category A. Infectious substances in Category B shall be assigned to UN 3373.

NOTE: *The proper shipping name of UN 3373 is “BIOLOGICAL SUBSTANCE, CATEGORY B”.*

Exemptions

Substances that do not contain infectious substances or that are unlikely to cause disease in humans or animals are not subject to dangerous goods regulations, unless they meet the criteria for inclusion in another class.

Substances containing microorganisms which are non-pathogenic to humans or animals are not subject to dangerous goods regulations, unless they meet the criteria for inclusion in another class.

Substances in a form that any present pathogens have been neutralized or inactivated such that they no longer pose a health risk are not subject to dangerous goods regulations, unless they meet the criteria for inclusion in another class.

- ❖ **NOTE:** *Medical equipment which has been drained of free liquid is deemed to meet the requirements of this paragraph and is not subject to dangerous goods regulations.*

Environmental samples (including food and water samples) which are not considered to pose a significant risk of infection are not subject to dangerous goods regulations, unless they meet the criteria for inclusion in another class.

- ❖ *Dried blood spots, collected by applying a drop of blood onto absorbent material are not subject to dangerous goods regulations.*
- ❖ *Faecal occult blood screening samples are not subject to dangerous goods regulations.*
- ❖ *Blood or blood components which have been collected for the purposes of transfusion or for the preparation of blood products to be used for transfusion or transplantation and any tissues or organs intended for use in transplantation as well as samples drawn in connection with such purposes are not subject to dangerous goods regulations.*
- ❖ *Human or animal specimens (patient specimens) for which there is minimal likelihood that pathogens are present are not subject to dangerous goods regulations if the specimen is transported in a packaging which will prevent any leakage and which is marked with the words “Exempt human specimen” or “Exempt animal specimen”, as appropriate. The packaging should meet the following conditions:*
 - a) *The packaging should consist of three components:*
 - i) *a leak-proof primary receptacle(s);*
 - ii) *a leak-proof secondary packaging; and*
 - iii) *an outer packaging of adequate strength for its capacity, mass and intended use, and with at least one surface having minimum dimensions of 100 mm × 100 mm;*
 - b) *For liquids, absorbent material in sufficient quantity to absorb the entire contents should be placed between the primary receptacle(s) and the secondary packaging so that, during transport, any release or leak of a liquid substance will not reach the outer packaging and will not compromise the integrity of the cushioning material;*
 - c) *When multiple fragile primary receptacles are placed in a single secondary packaging, they should be either individually wrapped or separated to prevent contact between them.*

NOTE 1: *An element of professional judgment is required to determine if a substance is exempt under this paragraph. That judgment should be based on the known medical history, symptoms and individual circumstances of the source, human or animal, and endemic local conditions. Examples of specimens which may be transported under this paragraph include the blood or urine tests to monitor cholesterol levels, blood glucose levels, hormone levels, or prostate specific antigen (PSA); those required to monitor organ function such as heart, liver or kidney function for humans or animals with non-infectious diseases, or therapeutic drug monitoring; those conducted for insurance or employment purposes and are intended to determine the presence of drugs or alcohol; pregnancy test; biopsies to detect cancer; and antibody detection in humans or animals in the absence of any concern for infection (e.g. evaluation of vaccine induced immunity, diagnosis of autoimmune disease, etc.).*

NOTE 2: *For air transport, packagings for specimens exempted under this paragraph shall meet the conditions in (a) to (c).*

Except for:

- (a) *Medical waste (UN 3291);*
- (b) *Medical devices or equipment contaminated with or containing infectious substances in Category A (UN 2814 or UN 2900); and*
- (c) *Medical devices or equipment contaminated with or containing other dangerous goods that meet the definition of another hazard class,*

medical devices or equipment potentially contaminated with or containing infectious substances which are being transported for disinfection, cleaning, sterilization, repair, or equipment evaluation are not subject to the provisions of dangerous goods regulations if packed in packagings designed and constructed in such a way that, under normal conditions of transport, they cannot break, be punctured or leak their contents. Packagings shall be designed to meet specific construction requirements – this is not considered further in these guidelines.

These packagings shall meet general packaging requirements not considered further in these guidelines, and be capable of retaining the medical devices and equipment when dropped from a height of 1.2 m. For air transport, additional requirements may apply.

The packaging shall be marked “USED MEDICAL DEVICE” or “USED MEDICAL EQUIPMENT”. When using overpacks, these shall be marked in the same way, except when the inscription remains visible.

Biological products

For the purposes of transport, biological products are divided into two groups:

- (a) *those which are manufactured and packaged in accordance with the requirements of appropriate national authorities and transported for the purposes of final packaging or distribution, and use for personal health care by medical professionals or individuals. Substances in this group are not subject to dangerous goods regulations;*
- (b) *those which do not fall under paragraph (a) and are known or reasonably believed to contain infectious substances and which meet the criteria for inclusion in Category A or Category B. Substances in this group shall be assigned to UN 2814, UN 2900 or UN 3373, as appropriate.*

NOTE: *Some licensed biological products may present a biohazard only in certain parts of the world. In that case, competent authorities may require these biological products to be in compliance with local requirements for infectious substances or may impose other restrictions.*

Genetically modified microorganisms and organisms

GMMOs or GMOs that do not meet the definition of toxic substances or infectious substances shall be assigned to UN 3245. GMMOs and GMOs assigned to UN 3245 shall be shipped following Packing Instruction P904 (ICAO/IATA PI959) – this is not considered further in these guidelines.

NOTE: *The proper shipping name for UN 3245 is “GENETICALLY MODIFIED MICRO-ORGANISMS” or “GENETICALLY MODIFIED ORGANISMS”.*

Medical or clinical wastes

Medical or clinical wastes containing Category A infectious substances shall be assigned to UN 2814 or UN 2900 as appropriate. Medical or clinical wastes containing infectious substances in Category B,

or which are reasonably believed to have a low probability of containing infectious substances, shall be assigned to UN 3291 and shipped following Packing Instruction P621 (ICAO/IATA PI622) – this is not considered further in these guidelines. For the assignment, international, regional or national waste catalogues may be taken into account.

NOTE: *The proper shipping name for UN 3291 is “CLINICAL WASTE, UNSPECIFIED, N.O.S.” or “(BIO) MEDICAL WASTE, N.O.S.” or “REGULATED MEDICAL WASTE, N.O.S.”.*

Decontaminated medical or clinical wastes which previously contained infectious substances are not subject to dangerous goods regulations unless they meet the criteria for inclusion in another class.

The bulk transport of wastes of Division 6.2 (UN 3291) is permitted according to provisions not further considered in these guidelines.

Infected animals

Unless an infectious substance cannot be consigned by any other means, live animals shall not be used to consign such a substance. A live animal which has been intentionally infected and is known or suspected to contain an infectious substance shall only be transported under terms and conditions approved by the competent authority.

Animal material affected by pathogens of Category A or which could be assigned to Category A in cultures only, shall be assigned to UN 2814 or UN 2900 as appropriate. Animal material affected by pathogens of Category B other than those which would be assigned to Category A if they were in cultures shall be assigned to UN 3373.

The bulk transport of animal material containing infectious substances (UN 2814, 2900 and 3373) is authorized according to provisions not further considered in these guidelines.

General preparation of shipments for transport

Because of the differences in the hazards posed by Category A infectious substances (UN 2814 and UN 2900) and Category B infectious substances (UN 3373), there are variations in the packaging, labelling and documentation requirements for the two categories. The packaging requirements are determined by UNCETDG and are set out as Packing Instructions P620 and P650, reproduced in Annexes 3 and 4, respectively. The requirements are subject to change and regular upgrade by the organizations mentioned. The current packaging requirements are described below.

Note 1: Hand carriage of Category A and Category B infectious substances and transport of these materials in diplomatic pouches are strictly prohibited by international air carriers.

Note 2: Inner packagings containing infectious substances shall not be consolidated with inner packagings containing unrelated types of goods.

Shippers of infectious substances shall ensure that packages are prepared in such a manner that they arrive at their destination in good condition and present no hazard to persons or animals during transport.

Basic triple packaging system

This system of packaging shall be used for all infectious substances. It consists of three layers as follows:

- Primary receptacle. A primary watertight, leak-proof receptacle containing the specimen. The receptacle is packaged with enough absorbent material to absorb all fluid in case of breakage or leakage.
- Secondary packaging. A second durable, watertight, leak-proof packaging to enclose and protect the primary receptacle(s). Several cushioned primary receptacles may be placed in one secondary packaging, but sufficient additional absorbent material shall be used to absorb all fluid in case of breakage or leakage.
- Outer packaging. Secondary packagings are placed in outer shipping packagings with suitable cushioning material. Outer packagings protect their contents from outside influences, such as physical damage, while in transit. The smallest overall external dimension shall be 10 x 10 cm.

Each completed package is normally required to be correctly marked, labelled and accompanied with appropriate shipping documents (as applicable). The requirements for these aspects are described below.

Packaging, labelling and documentation requirements for infectious substances in Category A

Packaging

Infectious substances in Category A may only be transported in packaging that meets the United Nations class 6.2 specifications and complies with Packing Instruction P620 (see Annex 3; Figure 1). This ensures that strict performance criteria are met; tests for compliance with these criteria include a 9-metre drop test, a puncture test, a pressure test and a stacking test. The outer packaging shall bear the United Nations packaging specification marking (Figure 2), which indicates that the packaging has passed the performance tests to the satisfaction of the competent authority.

The primary receptacle or the secondary packaging shall be capable of withstanding a pressure differential of not less than 95 kPa. The United Nations packaging specification marking alone does not indicate that a test for this has been undertaken, and packaging users should ask their suppliers whether the completed package meets this requirement.

There is no comprehensive list of suppliers of packagings that comply with Packing Instruction P620. However, an Internet search using a suitable international or national search engine usually provides appropriate information, as well as access to national regulations. Search phrases such as “UN packaging” and “UN infectious substance packaging” produce extensive results. Carriers and forwarding agents should also be able to supply details of local suppliers or local companies that can provide such information.

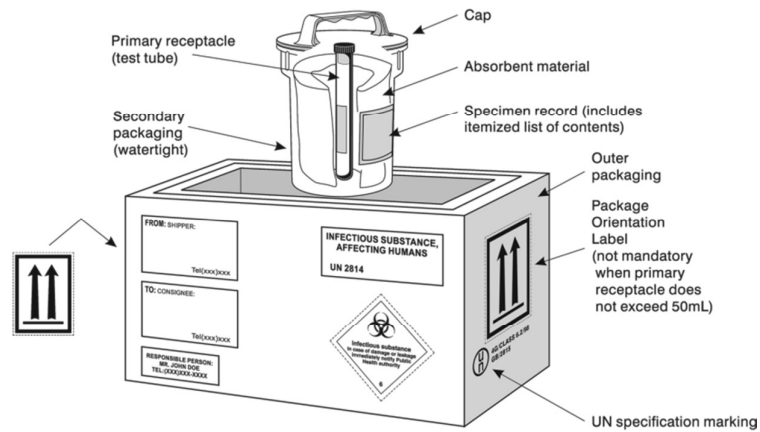

Figure 1. Example of triple packaging system for the packaging and labelling of Category A infectious substances (Figure kindly provided by IATA, Montreal, Canada)

	4G/Class 6.2/10/GB/2470
<p>This marking comprises:</p> <ul style="list-style-type: none"> • the United Nations packaging symbol • an indication of the type of packaging (in this example a fibreboard box (4G)) • an indication that the packaging has been specially tested to ensure that it meets the requirements for Category A infectious substances (Class 6.2) • the last two digits of the year of manufacture (in this example 2010) • the competent state authority that has authorized the allocation of the mark (in this example GB, signifying Great Britain) • the manufacturer's code specified by the competent authority (in this example 2470) <p>Users shall be provided with clear instructions as to how the package should be filled and prepared for transport.</p>	

Figure 2. UN specification marking for Category A infectious substances (UN 2814 and UN 2900)

For surface transport there is no maximum quantity per package. For air transport the limits per package are as follows:

- 50 ml or 50 g for passenger aircraft
- 4 litres or 4 kg for cargo aircraft.

Any primary receptacle with a capacity of more than 50 ml shall be oriented in the outer packaging so that the closures are upwards. Orientation labels (“UP” arrows) shall be affixed to two opposite sides of the outer packaging.

Marking

Packages are marked to provide information about the contents of the package, the nature of the hazard, and the packaging standards applied. All markings on packages or overpacks shall be placed in such a way that they are clearly visible and not covered by any other label or marking. Each package shall display the following information on the outer packaging or the overpack.

- the shipper's (sender's, consignor's) name and address
- the telephone number of a responsible person, knowledgeable about the shipment
- the receiver's (consignee's) name and address
- the United Nations number followed by the proper shipping name (UN 2814 "INFECTIOUS SUBSTANCE, AFFECTING HUMANS" or UN 2900 "INFECTIOUS SUBSTANCE, AFFECTING ANIMALS only", as appropriate). Technical names need not be shown on the package.
- temperature storage requirements (optional)
- when dry ice or liquid nitrogen is used: the technical name of the refrigerant, the appropriate United Nations number, and the net quantity.

Labelling

There are two types of labels: (a) hazard labels in the form of a square set at an angle of 45° (diamond-shaped) are required for most dangerous goods in all classes; (b) handling labels in various shapes are required, either alone or in addition to hazard labels, for some dangerous goods. Specific hazard label(s) shall be affixed to the outside of each package for all dangerous goods to be shipped (unless specifically exempted). The hazard labels shown in Figures 3–7 are of importance for infectious substances in Category A:



Label name: Infectious substance
 Minimum dimensions: 100 × 100 mm
 (for small packages: 50 × 50 mm)
 No. of labels per package: 1
 Colour: Black and white

The words "INFECTIOUS SUBSTANCE" shall be shown. The statement "In case of damage or leakage immediately notify a Public Health Authority" is required in some countries.

Figure 3. Hazard label for Category A infectious substances and for genetically modified microorganisms and organisms that meet the definition of an infectious substance, Category A

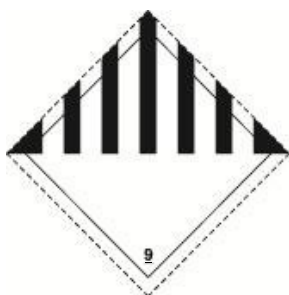

Label name: Miscellaneous dangerous substances
 Minimum dimensions: 100 × 100 mm
 (for small packages: 50 × 50 mm)
 No. of labels per package: 1
 Colour: Black and white

Figure 4. Hazard label for certain noninfectious genetically modified microorganisms and organisms (UN 3245) and for carbon dioxide, solid (dry ice) (UN 1845); substances packed in dry ice (see section on Refrigerants) shall bear this label in addition to the primary risk label (e.g. the label shown in

Figure 3 for Category A infectious substances, the marking shown in Figure 10 for Category B infectious substances)



Label name:	Non flammable, non-toxic gas
Minimum dimensions:	100 × 100 mm
(for small packages:	50 × 50 mm)
No. of labels per package:	1
Colour:	Green and white or green and black

Figure 5. Hazard label for liquid nitrogen; substances packed using liquid nitrogen (see section on Refrigerants) shall bear this label in addition to the primary risk label (e.g. the label shown in Figure 3 for Category A infectious substances, the marking shown in Figure 10 for Category B infectious substances)



Label name:	Cryogenic liquid
Minimum dimensions:	Standard A7: 74 × 105 mm
No. of labels per package:	1
Colour:	Green and white

Figure 6. Handling label for cryogenic liquids; for transport by air, where cryogenic liquids (deeply refrigerated liquefied gases) are used (see section on Refrigerants), this label shall be affixed to insulated vessels or flasks used as outer packaging in addition to the labels or markings shown in Figures 3, 5 and 10, as appropriate

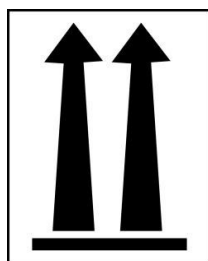

Label name:	Orientation label
Minimum dimensions:	Standard A7: 74 × 105 mm
No. per package:	2 on opposite sides
Colour:	Black and white or red and white

The words “THIS SIDE UP” or “THIS END UP” may also be displayed on the top cover of the package.

Figure 7. Orientation label to indicate position of closures on the primary receptacles; for the air transport of quantities of liquid infectious substances in Category A that exceed 50 ml per primary receptacle, this label shall be affixed to two opposite sides of the package with the arrows pointing in the right direction, in addition to the label shown in Figure 3

Instructions for the labelling of overpacks are given in the section on Overpacks.

Documentation

The following shipping documents are required.

To be prepared and signed by the shipper:

- for air: the shipper's Declaration for Dangerous Goods (Figure 8 shows an example)
- a packing list/proforma invoice that includes the receiver's address, the number of packages, detail of contents, weight, value (Note: for international transport, a minimal value shall be indicated, for customs purposes, if the items are supplied free of charge)
- an import and/or export permit and/or declaration if required

To be prepared by the shipper or the shipper's agent:

- an air waybill for air transport or equivalent documents for road, rail and sea shipments.

For UN 2814 and UN 2900, an itemized list of contents shall be enclosed between the secondary packaging and the outer packaging.

For the purposes of documentation, the proper shipping name shall be supplemented with the technical name. Technical names need not be shown on the package. When the infectious substances to be transported are unknown, but suspected of meeting the criteria for inclusion in category A and assignment to UN 2814 or UN 2900, the words "suspected Category A infectious substance" shall be shown, in parentheses, following the proper shipping name on the transport document, but not on the outer packagings.

SHIPPER'S DECLARATION FOR DANGEROUS GOODS

Shipper Dr XY Orange, tel 0789 456 123 Childrens' hospital 4, Splendid Street 12345 Beauticity Nicecountry		Air Waybill No. 543 7654 9876 Page 1 of 1 Pages Shipper's Reference Number (optional)				
Consignee Dr AB Normal, tel 03210 987 4568 Virobactfung Laboratories 6, Many Way 98765 Myplace Hercountry						
<i>Two completed and signed copies of this declaration must be handed to the operator.</i>		WARNING Failure to comply in all aspects with the applicable Dangerous Goods Regulations may be in breach of the applicable law, subject to legal penalties.				
TRANSPORT DETAILS This shipment is within the limitations prescribed for: (Delete non-applicable)						
Airport of Departure: Amleaving						
<input type="checkbox"/> PASSENGER AND CARGO AIRCRAFT	<input checked="" type="checkbox"/> CARGO AIRCRAFT ONLY	Airport of Destination <p style="text-align: center;">Willgetthere</p>				
		Shipment Type (Delete non-applicable) <input type="checkbox"/> NON-RADIOACTIVE <input checked="" type="checkbox"/> RADIOACTIVE				
NATURE AND QUANTITY OF DANGEROUS GOODS						
Dangerous Goods Identification						
UN or ID No.	Proper Shipping Name	Class or Division (Subsidiary Risk)	Packing Group	Quantity and Type of Packing	Packing Inst.	Authorization
UN 2814	Infectious substance, affecting humans (Ebola virus)	6.2		50ml	620	
UN 1845	Dry ice	9		20kg All packed in one fibreboard box	954	
Additional Handling Information Emergency contact: Dr Orange tel 0789 456 123						
I hereby declare that the contents of this consignment are fully and accurately described above by the proper shipping name, and are classified, packaged, marked and labelled/placarded, and are in all respects in proper condition for transport according to applicable international and national governmental regulations.				Name/Title of Signatory Dr XY Orange Goods Dispatch Place and Date: Beauticity 18 June 2010 Signature (see warning above)		

Figure 8. Example of a completed shipper's Declaration for Dangerous Goods

Packaging, labelling and documentation requirements for infectious substances in Category B

Packaging

The triple packaging system continues to apply, including for local surface transport. Testing documents are not required, however. It may be possible to source packagings locally rather than finding an authorized supplier, provided that the packaging manufacturer and the shipper can comply fully with the requirements of P650 (see Annex 4; Figure 9).

As for P620, there is no comprehensive list of suppliers of packagings that comply with Packing Instruction P650. However, an Internet search using a suitable international or national search engine usually provides appropriate information, as well as access to national regulations. Search phrases such as “UN packaging” and “UN infectious substance packaging” produce extensive results. Carriers and forwarding agents should also be able to supply details of local suppliers or local companies that can provide such information.

To ensure correct preparation for transport, packaging manufacturers and subsequent distributors shall provide clear instructions to the consignor or persons preparing packages (e.g. patients) on how the packaging should be filled and closed.

For surface transport there is no maximum quantity per package. For air transport:

- no primary receptacle shall exceed 1 litre and the outer packaging must not contain more than 4 litres (for liquids)
- except for packages containing body parts, organs or whole bodies, the outer packaging must not contain more than 4 kg (for solids).

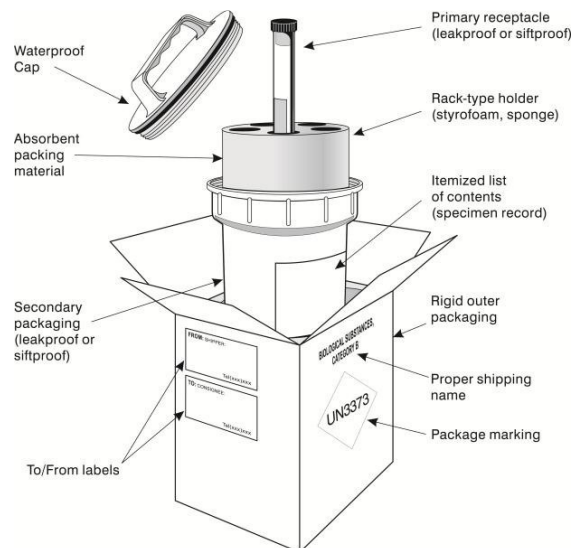

Figure 9. Example of the triple packaging system for the packing and labelling of Category B infectious substances (Figure kindly provided by IATA, Montreal, Canada)

Provided all the requirements of P650 are met, there are no other transport requirements. P650 incorporates all that is needed to make a shipment for Category B infectious substances.

Marking

Each package shall display the following information:

- for air: the shipper's (sender's, consignor's) name, address and telephone number
- for air: the telephone number of a responsible person, knowledgeable about the shipment
- the receiver's (consignee's) name, address and telephone number
- the proper shipping name ("BIOLOGICAL SUBSTANCE, CATEGORY B") adjacent to the diamond-shaped mark shown in Figure 10
- temperature storage requirements (optional).

The marking shown in Figure 10 is used for shipments of Category B infectious substances.



- Minimum dimension: the width of the line forming the square shall be at least 2 mm, and the letters and numbers shall be at least 6 mm high. For air transport, each side of the square shall have a length of at least 50 mm
- Colour: none specified, provided the mark is displayed on the external surface of the outer packaging on a background of contrasting colour and that it is clearly visible and legible
- The words "BIOLOGICAL SUBSTANCE, CATEGORY B" in letters at least 6 mm high shall be displayed adjacent to the mark.

❖ Figure 10. Marking for infectious substances of Category B

Note: For air transport:

- when dry ice (solid carbon dioxide) is used (see section on Refrigerants), the label shown in Figure 4 shall be applied
- for cryogenic liquids (see section on Refrigerants) the labels shown in Figures 5 and 6 shall also be affixed.

Documentation

Dangerous goods documentation (including a shipper's declaration) is not required for Category B infectious substances. The following shipping documents are required.

To be prepared and signed by the shipper (sender, consignor):

- for international shipments: a packing list/proforma invoice that includes the shipper's and the receiver's address, the number of packages, detail of contents, weight, value (Note: the statement "no commercial value" shall appear if the items are supplied free of charge)
- an import and/or export permit and/or declaration if required.

To be prepared by the shipper or the shipper's agent:

- an air waybill for air transport or equivalent documents for road, rail and sea journeys.

A flowchart to help with the classification of infectious substances and patient specimens is shown in Annex 5.

Overpacks

"Overpack" is the term used when several packages are combined to form one unit and sent to the same destination by a single shipper. When refrigerants are used to protect contents, the overpacks may comprise insulated vessels or flasks. Whenever an overpack is used, the required marks and labels shown on the outer packaging must be repeated on the outermost layer of the overpack. This requirement applies to infectious substances in Categories A and B. Overpacks are also required to be marked with the word "overpack".

NOTE: Do not reproduce the UN specification marking on the overpack.

Reusing packaging materials

Shipping packages can be reused. If shippers plan on reusing a package, it must be appropriately disinfected. Before reusing a package, the shipper must make sure all markings and labels reflect the substances actually being shipped. If the shipper plans on shipping an empty package, all non-applicable markings and labels must be removed or covered.

Shipping empty packagings

Before an empty package is returned to the shipper, or sent elsewhere, it must be appropriately disinfected or sterilized to nullify any hazard. Any label or marking indicating that it had contained an infectious substance shall be removed or covered.

Refrigerants

Refrigerants may be used to stabilize infectious substances in Categories A and B during transit.

Packed infectious substances requiring cooling assigned to packing instructions P620 or P650 shall meet the appropriate requirements of that packing instruction.

Ice, ice pads or dry ice shall be placed outside the secondary receptacle or in an outer packaging or in an overpack. Wet ice shall be placed in a leak-proof container; the outer packaging or overpack shall also be leak-proof. Dry ice must not be placed inside the primary or secondary receptacle because of the risk of explosions. A specially designed insulated packaging may be used to contain dry ice. The packaging must permit the release of carbon dioxide gas if dry ice is used. Packing instruction P003 (ICAO/IATA PI954) shall be observed.

The secondary receptacle shall be secured within the outer package to maintain the original orientation of the inner packages after the refrigerant has melted or dissipated.

- ❖ If dry ice is used to ship infectious substances in Category A, the details shall appear on the shipper's Declaration for Dangerous Goods. If dry ice is used to ship infectious substances in Category B or Exempt samples, the shipper's Declaration of Dangerous Goods is not required. In any case, the outermost packaging shall carry the hazard label for dry ice (see Figure 4), the appropriate markings, including the UN number and the proper shipping name followed by the words "AS COOLANT", *for example: UN 1845, CARBON DIOXIDE, SOLID, AS COOLANT.* and an indication of the net quantity of dry ice in kilograms.

If liquid nitrogen is used as a refrigerant, special arrangements shall be made in advance with the carrier. Primary receptacles shall be capable of withstanding extremely low temperatures, and packaging and documentation requirements for liquid nitrogen shall be observed. In particular, the outermost packaging shall carry the hazard label for liquid nitrogen (see Figure 5). For air transport, the handling label for cryogenic liquids shall also be affixed (see Figure 6) – this is not considered further in these guidelines.

When shipping with liquid nitrogen, "dry shippers" can be used. Correctly prepared "dry shippers" do not contain free liquid nitrogen. While liquid nitrogen is a regulated dangerous good, a properly prepared "dry shipper" is not. When shipping with "dry shippers", the dangerous goods label for class 2 (non-flammable, non-toxic gases) is NOT required. Shippers must properly mark and label the outside of dry shipper packages containing infectious substances. Appropriate documentation should discuss the presence of infectious substances. For Category A this information will be included in the Dangerous Goods Declaration. For Category B and Exempt packages this information should be provided on the Air Waybill.

Training

The dangerous goods regulations require all personnel involved in transport to undergo appropriate training.

For the transport of Category A infectious substances, personnel must undergo training in accordance with the modal requirements. This can involve attendance at approved courses and passing examinations.

For the transport of Category B infectious substances there is a requirement that clear instructions on the use of the packaging are supplied to the user; this is regarded as sufficient "training" for the shipping of these substances. However, if such specimens are consigned with other dangerous goods (e.g. flammable liquids, radioactive materials, liquefied gases, etc.), then personnel must be trained in the proper procedures for their transport.

Training and awareness are important for all personnel involved in the transport of Category B infectious substances. Training of personnel, for example via consultation of guidance documents like this one, while not formally required by the modal regulations, is recommended and encouraged. Only through appropriate guidance and training can shippers ensure that the classification of the substance to be shipped is correct, and that proper packaging is selected and prepared. Carriers and other employers of transport workers should train their personnel in the appropriate procedures for recognizing and handling packages containing infectious substances and in how to address spills and protect themselves from exposure.

- ❖ *Records of training received shall be kept by the employer and made available to the employee or competent authority, upon request. Records shall be kept by the employer for a period of time established by the competent authority. The training mentioned above shall be provided or verified upon employment in a position involving the transport of infectious substances and shall be periodically supplemented with retraining as deemed appropriate by the competent authority.*

Recommendations for countries that have not adopted the United Nations system

The recommendations set out above apply wherever the United Nations system for the transport of infectious substances has been adopted. WHO encourages all countries to adopt this system, and recommends those that have not yet done so to follow its provisions. However, the principles described above are not intended to supersede national or local requirements.

Transport planning

It is the responsibility of the shipper to ensure the correct classification, packaging, labelling, and documentation of all infectious substances destined for transport.

The efficient transport and transfer of infectious substances requires good coordination between the sender, the carrier and the receiver to ensure that the material is transported safely and arrives on time and in good condition. Such coordination depends upon well-established communications and a good working relationship between the three parties.

The carriage of any goods whether dangerous or not, is a commercial matter for a carrier. The dangerous goods rules described in these guidelines reflect governmental legal requirements. Indeed, different countries may have adopted State variations to the United Nations Model Regulations. In addition, a carrier that does not wish to carry particular goods is under no legal obligation to do so. Many carriers (airlines, haulers and shipping lines) are “private carriers” and have the right to refuse to carry goods or add additional requirements. In recent years it has become clear that some carriers are indeed refusing to carry certain goods or are adding extra conditions. Provided such conditions do not conflict with the legal requirements, this type of action is not illegal.

ICAO and IATA list the main carrier restrictions in force among airlines. Some airlines will not carry dangerous goods at all, while others will carry only a very limited range of goods. As carrier restrictions for the different modes of transport are not published centrally, harmonization between stakeholders is essential. The shipper (sender, consignor), carrier and the receiver (consignee) have specific responsibilities in ensuring successful transportation.

The shipper (sender, consignor)

- Makes advance arrangements with the receiver including investigating the need for import/export permits
- Makes advance arrangements with the carrier to ensure:
 - that the shipment will be accepted for appropriate transport
 - that the shipment (direct transport if possible) is undertaken by the most direct routing
- Prepares necessary documentation, including permits, dispatch and shipping documents
- Notifies the receiver of transportation arrangements once these have been made, well in advance of the expected arrival time.

The carrier

- Provides advice to the sender regarding the necessary shipping documents and instructions for their completion
- Provides advice to the sender about correct packaging
- Assists the sender in arranging the most direct routing and then confirms the routing
- Maintains and archives the documentation for shipment and transport.

The receiver (consignee)

- Obtains the necessary authorization(s) from national authorities for the importation of the material
- Provides the sender with the required import permit(s), letter(s) of authorization, or other document(s) required by the national authorities
- Arranges for the most timely and efficient collection on arrival
- Should acknowledge receipt to the sender.

Shipments should not be dispatched until:

- Advance arrangements have been made between the sender, carrier and receiver
- The shipper has confirmed with the national authorities that the material may be legally exported
- The receiver has confirmed with the national authorities that the material may be legally imported
- The receiver has confirmed that there will be no delay incurred in the delivery of the package to its destination.

Requirements for air mail

Infectious substances in Category A will not be accepted for shipment through postal services.

Infectious substances in Category B may be shipped by registered air mail, and the Universal Postal Union recommends the following procedure.

The basic triple packaging system is used with the same requirements as for other means of transport. The address label shall display the word “*Lettre*” or “Letter” and the green Customs Declaration Label for Postal Mail is required for international mailing. “BIOLOGICAL SUBSTANCE, CATEGORY B” shall be identified with the white diamond label with black letters “UN 3373” (see Figure 10).

Local/international restrictions may be in force. Prior contact should therefore be made with the national public operator to ascertain whether the packaged material will be accepted by the postal service in question.

Spill clean-up procedure

The appropriate response in the event of exposure to any infectious substance is to wash or disinfect the affected area as soon as possible, regardless of the agent. Even if an infectious substance comes into contact with non-intact skin, washing of the affected area with soap and water or with an antiseptic solution can reduce the risk of infection. Medical advice should be obtained any time there is a suspected exposure to infectious substances resulting from a damaged package. The following procedure for clean-up can be used for spills of all infectious substances including blood. The person must be trained on such procedure before performing these steps:

1. Wear gloves and protecting clothing, including face and eye protection if indicated.
2. Cover the spill with a cloth or paper towels to contain it.
3. Pour an appropriate disinfectant over the cloth or paper towels and the immediately surrounding area (5% bleach solutions are generally appropriate, but for spills on aircraft, quaternary ammonium disinfectants should be used).

4. Apply the disinfectant concentrically beginning at the outer margin of the spill area, working towards the centre.
5. After about 30 min, clear away the materials. If there is broken glass or other sharps are involved, use a dustpan or a piece of stiff cardboard to collect the materials and deposit them into a puncture-resistant container for disposal.
6. Clean and disinfect the area of the spillage (if necessary, repeat steps 2–5).
7. Dispose of contaminated materials into a leak-proof, puncture-resistant waste disposal container.
8. After successful disinfection, report the incident to the competent authority and inform them that the site has been decontaminated (see Incident reporting below).

Detailed information on disinfectants and their recommended use can be found in *Laboratory biosafety manual*, 3rd ed., Geneva, World Health Organization, 2004.

Incident reporting

No reports of infections resulting from transport-related exposures have been documented other than the anthrax letters of 2001 in the USA. There have been reports of the transmission of acute respiratory infections and tuberculosis associated with air travel, but these were attributed to direct person-to-person contact and not to packaging problems or shipping incidents.

Statistical data collected by a group of central laboratories showed the efficacy of packaging compliant with P650 and P620 in assuring that infectious substances are transported without leakage and loss of materials. For the 4.92 million primary containers shipped in 2003 to any of the worldwide regional offices of these central laboratories, just 106 breakages, 0.002% of the total number, were recorded. Moreover, the leakages that did occur were all contained by the absorbent material, and no damage to secondary containers or outer packagings was reported.

The various international modal regulations require the reporting of incidents to the relevant competent transport authorities in addition to the necessary health authorities. This applies to both categories of infectious substances, but particularly to those in Category A.

Annex 1

Additional information on the United Nations System for the Transport of Dangerous Goods

The United Nations dangerous goods web site provides comprehensive detail concerning the United Nations Recommendations on the Transport of Dangerous Goods. It also provides links to the modal agencies:

<http://www.unece.org/trans/danger/danger.htm>

The site below provides the full text of the United Nations Recommendations, which can be downloaded in PDF format. Readers wishing to see the text relating to the transport of infectious substances should download Part 2, Part 4 and Part 5 and Chapter 6.3 as downloadable text (It covers construction and performance requirements for packagings intended to contain infectious substances) of the Recommendations:

❖ http://www.unece.org/trans/danger/publi/unrec/rev18/18files_e.html

❖ The site below provides the full text of the European Agreement concerning the International Carriage of Dangerous Goods by Road (ADR) of 2015.

<http://www.unece.org/trans/danger/publi/adr/adr2015/15contentse.html>

The amendments to ADR which come into force on 1 January 2015 may be found on the same site at:

http://www.unece.org/trans/danger/publi/adr/adr2013_amend.html

All these texts may be downloaded in PDF format. Readers wishing to study the text relating to the transport of infectious substances should download Part 1 (Chapters 1.3, 1.4 and 1.10), Part 2 (section 2.2.62), Part 4 (Chapter 4.1, including section 4.1.4.1 packing instructions P620 and P650 (or, for medical waste P621, IBC620 and LP620), and section 4.1.8), Part 5 and Part 6 (Chapter 6.3). Some provisions in Parts 7 and 8 have also to be complied with for the transport operation.

Contracting parties to the various conventions for the transport of dangerous goods can be found on a number of web sites:

❖ **Air** ICAO: <http://www.icao.int/safety/DangerousGoods/Pages/technical-instructions.aspx> (accessed 24 November 2014) and <http://www.icao.int/safety/DangerousGoods/Pages/StateVariationPage.aspx>

❖ **Rail** RID: <http://www.otif.org/>. RID is primarily for the countries of Europe, North Africa and the Middle East. There are a number of countries (mainly Eastern Europe and Asia that apply RID through the Organization for Cooperation of Railways (OSJD); details of RID membership can be found at <http://www.otif.org/en/about-otif/addresses-and-useful-links/member-states.html>. Regulations concerning the International Carriage of Dangerous Goods by Rail (RID) can be found in this link: <http://www.otif.org/en/publications/rid-2015.html>

Road ADR: http://www.unece.org/trans/danger/publi/adr/country-info_e.htm (lists competent authorities)

Sea IMO: <http://www.imo.org>

Post UPU: <http://www.upu.int/>

Annex 2

Examples of infectious substances included in Category A

- ❖ The table provided below is an indicative list taken from the 18th edition of the United Nations Model Regulations. In this table, the microorganisms written in italics are bacteria, mycoplasmas, rickettsiae or fungi.

INDICATIVE EXAMPLES OF INFECTIOUS SUBSTANCES INCLUDED IN CATEGORY A IN ANY FORM UNLESS OTHERWISE INDICATED	
UN Number and Proper Shipping Name	Microorganism
UN 2814 Infectious substance, affecting humans	<i>Bacillus anthracis</i> (cultures only)
	<i>Brucella abortus</i> (cultures only)
	<i>Brucella melitensis</i> (cultures only)
	<i>Brucella suis</i> (cultures only)
	<i>Burkholderia mallei</i> – <i>Pseudomonas mallei</i> – glanders (cultures only)
	<i>Burkholderia pseudomallei</i> – <i>Pseudomonas pseudomallei</i> (cultures only)
	<i>Chlamydia psittaci</i> – avian strains (cultures only)
	<i>Clostridium botulinum</i> (cultures only)
	<i>Coccidioides immitis</i> (cultures only)
	<i>Coxiella burnetii</i> (cultures only)
	Crimean-Congo haemorrhagic fever virus
	Dengue virus (cultures only)
	Eastern equine encephalitis virus (cultures only)
	<i>Escherichia coli</i> , verotoxigenic (cultures only) ¹
	Ebola virus
	Flexal virus
	<i>Francisella tularensis</i> (cultures only)
	Guanarito virus
	Hantaan virus
	Hantaviruses causing haemorrhagic fever with renal syndrome
	Hendra virus
	Hepatitis B virus (cultures only)
	Herpes B virus (cultures only)
	Human immunodeficiency virus (cultures only)
	Highly pathogenic avian influenza virus (cultures only)
	Japanese Encephalitis virus (cultures only)
	Junin virus
	Kyasanur Forest disease virus
	Lassa virus
	Machupo virus
Marburg virus	
Monkeypox virus	
<i>Mycobacterium tuberculosis</i> (cultures only) ¹	
Nipah virus	

Continued on next page

¹ For surface transport (ADR) nevertheless, when the cultures are intended for diagnostic or clinical purposes, they may be classified as infectious substances of Category B.

INDICATIVE EXAMPLES OF INFECTIOUS SUBSTANCES INCLUDED IN CATEGORY A IN ANY FORM UNLESS OTHERWISE INDICATED	
	Omsk haemorrhagic fever virus
	Poliovirus (cultures only)
	Rabies virus (cultures only)
	<i>Rickettsia prowazekii</i> (cultures only)
	<i>Rickettsia rickettsii</i> (cultures only)
	Rift Valley fever virus (cultures only)
	Russian spring-summer encephalitis virus (cultures only)
	Sabia virus
	<i>Shigella dysenteriae type 1</i> (cultures only) ¹
	Tick-borne encephalitis virus (cultures only)
	Variola virus
	Venezuelan equine encephalitis virus (cultures only)
	West Nile virus (cultures only)
	Yellow fever virus (cultures only)
	<i>Yersinia pestis</i> (cultures only)
UN 2900 Infectious substance, affecting animals only	African swine fever virus (cultures only)
	Avian paramyxovirus Type 1 – Velogenic Newcastle disease virus (cultures only)
	Classical swine fever virus (cultures only)
	Foot and mouth disease virus (cultures only)
	Lumpy skin disease virus (cultures only)
	<i>Mycoplasma mycoides</i> – contagious bovine pleuropneumonia (cultures only)
	Peste des petits ruminants virus (cultures only)
	Rinderpest virus (cultures only)
	Sheep-pox virus (cultures only)
	Goatpox virus (cultures only)
	Swine vesicular disease virus (cultures only)
	Vesicular stomatitis virus (cultures only)

¹ For surface transport (ADR) nevertheless, when the cultures are intended for diagnostic or clinical purposes, they may be classified as infectious substances of Category B.

Annex 3

Packing Instruction P620

Infectious substances in Category A and designated as UN 2814 or UN 2900 may only be transported in packaging that meets the United Nations class 6.2 specifications and complies with Packing Instruction P620, which is reproduced below. The various provisions mentioned are set out in the United Nations Model Regulations.

NOTE: Variations applying to air transport are highlighted in grey.



P620	PACKING INSTRUCTION	P620
This instruction applies to UN 2814 and UN 2900.		
<p>The following packagings are authorized provided the special packing provisions described below are met: Packagings meeting the requirements of Chapter 6.3 and approved accordingly consisting of:</p> <p>(a) Inner packagings comprising:</p> <ul style="list-style-type: none"> (i) leakproof primary receptacle(s); (ii) a leakproof secondary packaging; (iii) other than for solid infectious substances, an absorbent material in sufficient quantity to absorb the entire contents placed between the primary receptacle(s) and the secondary packaging; if multiple fragile primary receptacles are placed in a single secondary packaging, they shall be either individually wrapped or separated so as to prevent contact between them; <p>(b) A rigid outer packaging.</p> <ul style="list-style-type: none"> Drums (1A1, 1A2, 1B1, 1B2, 1N1, 1N2, 1H1, 1H2, 1D, 1G); Boxes (4A, 4B, 4N, 4C1, 4C2, 4D, 4F, 4G, 4H1, 4H2); Jerricans (3A1, 3A2, 3B1, 3B2, 3H1, 3H2). <p>The smallest external dimension shall be not less than 100 mm (4 in).</p>		
<p>Additional requirements:</p> <ol style="list-style-type: none"> 1. Inner packagings containing infectious substances shall not be consolidated with inner packagings containing unrelated types of goods. Complete packages may be overpacked in accordance with the provisions of 1.2.1 and 5.1.2; such an overpack may contain dry ice. 2. Other than for exceptional consignments, e.g. whole organs which require special packaging, the following additional requirements shall apply: <ul style="list-style-type: none"> (a) Substances consigned at ambient temperatures or at a higher temperature. Primary receptacles shall be of glass, metal or plastics. Positive means of ensuring a leakproof seal shall be provided, e.g. a heat seal, a skirted stopper or a metal crimp seal. If screw caps are used, they shall be secured by positive means, e.g., tape, paraffin sealing tape or manufactured locking closure; (b) Substances consigned refrigerated or frozen. Ice, dry ice or other refrigerant shall be placed around the secondary packaging(s) or alternatively in an overpack with one or more complete packages marked in accordance with 6.3.3. Interior supports shall be provided to secure secondary packaging(s) or packages in position after the ice or dry ice has dissipated. If ice is used, the outer packaging or overpack shall be leakproof. If dry ice is used, the outer packaging or overpack shall permit the release of carbon dioxide gas. The primary receptacle and the secondary packaging shall maintain their integrity at the temperature of the refrigerant used; (c) Substances consigned in liquid nitrogen. Plastics primary receptacles capable of withstanding very low temperature shall be used. The secondary packaging shall also be capable of withstanding very low temperatures, and in most cases will need to be fitted over the primary receptacle individually. Provisions for the consignment of liquid nitrogen shall also be fulfilled. The primary receptacle and the secondary packaging shall maintain their integrity at the temperature of the liquid nitrogen; (d) Lyophilized substances may also be transported in primary receptacles that are flame-sealed glass ampoules or rubber-stoppered glass vials fitted with metal seals. 		

Continued on next page

3. Whatever the intended temperature of the consignment, the primary receptacle or the secondary packaging shall be capable of withstanding without leakage an internal pressure producing a pressure differential of not less than 95 kPa and temperatures in the range -40 °C to +55 °C (-40 °F to +130 °F).
4. Other dangerous goods shall not be packed in the same packaging as Division 6.2 infectious substances unless they are necessary for maintaining the viability, stabilizing or preventing degradation or neutralizing the hazards of the infectious substances. A quantity of 30 ml or less of dangerous goods included in Classes 3 (flammable liquids), 8 (corrosive substances) or 9 (miscellaneous dangerous substances and articles, including environmentally hazardous substances) may be packed in each primary receptacle containing infectious substances. These small quantities of dangerous goods of Classes 3, 8 or 9 are not subject to any additional requirements of these Regulations when packed in accordance with this packing instruction.
5. Alternative packagings for the transport of animal material may be authorized by the competent authority in accordance with the provisions of 4.1.3.7.

Special packing provisions

1. Shippers of infectious substances shall ensure that packages are prepared in such a manner that they arrive at their destination in good condition and present no hazard to persons or animals during transport.
2. An itemized list of contents shall be enclosed between the secondary packaging and the outer packaging. When the infectious substances to be transported are unknown, but suspected of meeting the criteria for inclusion in category A, the words "suspected category A infectious substance" shall be shown, in parenthesis, following the proper shipping name on the document inside the outer packaging.
3. Before an empty packaging is returned to the shipper, or sent elsewhere, it must be disinfected or sterilized to nullify any hazard and any label or marking indicating that it had contained an infectious substance must be removed or obliterated.

Annex 4

Packing Instruction P650

The text of United Nations Packing Instruction P650, in use for the transport of infectious substances in category B assigned to UN 3373 by all surface modes of transport is reproduced below. The shaded text on the right hand side indicates the ICAO variations to these instructions that apply to the transport by air. The various provisions mentioned are set out in the United Nations Model Regulations.

NOTE: Variations applying to air transport are displayed on a grey background.

P650	PACKING INSTRUCTION	P650
This packing instruction applies to UN 3373		on passenger and cargo aircraft, and cargo aircraft only (CAO).
<p>(1) The packaging shall be of good quality, strong enough to withstand the shocks and loadings normally encountered during transport, including trans-shipment between cargo transport units and between transport units and warehouses as well as any removal from a pallet or overpack for subsequent manual or mechanical handling. Packagings shall be constructed and closed to prevent any loss of contents that might be caused under normal conditions of transport by vibration or by changes in temperature, humidity or pressure.</p> <p>(2) The packaging shall consist of at least three components:</p> <p style="margin-left: 20px;">(a) a primary receptacle,</p> <p style="margin-left: 20px;">(b) a secondary packaging, and</p> <p style="margin-left: 20px;">(c) an outer packaging</p> <p style="margin-left: 20px;">of which either the secondary or the outer packaging shall be rigid</p> <div style="background-color: #e0e0e0; padding: 5px; margin-left: 300px; width: fit-content;">The outer packaging must be rigid.</div> <p>(3) Primary receptacles shall be packed in secondary packagings in such a way that, under normal conditions of transport, they cannot break, be punctured or leak their contents into the secondary packaging. Secondary packagings shall be secured in outer packagings with suitable cushioning material. Any leakage of the contents shall not compromise the integrity of the cushioning material or of the outer packaging.</p> <p>(4) For transport, the mark illustrated below shall be displayed on the external surface of the outer packaging on a background of a contrasting colour and shall be clearly visible and legible. The mark shall be in the form of a square set at an angle of 45° (diamond-shaped) with each side having a length of at least 50 mm; the width of the line shall be at least 2 mm and the letters and numbers shall be at least 6 mm high. The proper shipping name "BIOLOGICAL SUBSTANCE, CATEGORY B" in letters at least 6 mm high shall be marked on the outer packaging adjacent to the diamond-shaped mark.</p> <div style="text-align: center; margin: 10px 0;">  </div> <p>(5) At least one surface of the outer packaging must have a minimum dimension of 100 mm × 100 mm.</p> <p>(6) The completed package shall be capable of successfully passing the drop test in 6.3.5.3 as specified in 6.3.5.2 of these Regulations at a height of 1.2 m. Following the appropriate drop sequence, there shall be no leakage from the primary receptacle(s) which shall remain protected by absorbent material, when required, in the secondary packaging.</p>		

Continued on next page

<p>(7) For liquid substances</p> <p>(a) The primary receptacle(s) shall be leakproof;</p> <p>(b) The secondary packaging shall be leakproof;</p> <p>(c) If multiple fragile primary receptacles are placed in a single secondary packaging, they shall be either individually wrapped or separated to prevent contact between them;</p> <p>(d) Absorbent material shall be placed between the primary receptacle(s) and the secondary packaging. The absorbent material shall be in quantity sufficient to absorb the entire contents of the primary receptacle(s) so that any release of the liquid substance will not compromise the integrity of the cushioning material or of the outer packaging;</p> <p>(e) The primary receptacle or the secondary packaging shall be capable of withstanding, without leakage, an internal pressure of 95 kPa (0.95 bar).</p>	<p>and must not contain more than 1 litre;</p> <p>in the range of -40 °C to +55 °C (-40 °F to +130 °F).</p> <p>(f) The outer package must not contain more than 4 litres. This quantity excludes ice, dry ice or liquid nitrogen when used to keep specimens cold.</p>
<p>(8) For solid substances</p> <p>(a) The primary receptacle(s) shall be siftproof;</p> <p>(b) The secondary packaging shall be siftproof;</p> <p>(c) If multiple fragile primary receptacles are placed in a single secondary packaging, they shall be either individually wrapped or separated to prevent contact between them.</p>	<p>and must not exceed the outer packaging mass limit;</p> <p>(d) Except for packages containing body parts, organs or whole bodies, the outer package must not contain more than 4 kg. This quantity excludes ice, dry ice or liquid nitrogen when used to keep specimens cold;</p> <p>(e) If there is any doubt as to whether or not residual liquid may be present in the primary receptacle during transport then a packaging suitable for liquids, including absorbent materials, shall be used.</p>
<p>(9) Refrigerated or frozen specimens: Ice, dry ice and liquid nitrogen</p> <p>(a) When dry ice or liquid nitrogen is used as a coolant, the requirements of 5.5.3 shall apply. When used, ice shall be placed outside the secondary packagings or in the outer packaging or an overpack. Interior supports shall be provided to secure the secondary packagings in the original position. If ice is used, the outside packaging or overpack shall be leakproof.</p> <p>(b) The primary receptacle and the secondary packaging shall maintain their integrity at the temperature of the refrigerant used as well as the temperatures and the pressures which could result if refrigeration were lost.</p> <p>(10) When packages are placed in an overpack, the package markings required by this packing instruction shall either be clearly visible or be reproduced on the outside of the overpack.</p> <p>(11) Infectious substances assigned to UN 3373 which are packed and marked in accordance with this packing instruction are not subject to any other requirement in these Regulations.</p>	
<p>Infectious substances assigned to UN 3373 that are packed and marked in accordance with this packing instruction are not subject to any other requirement in these Instructions except for the following:</p> <p>(a) the name and address of the shipper and the receiver (consignee) must be provided on each package;</p>	

Continued on next page

	<ul style="list-style-type: none">(b) the name and telephone number of a person responsible must be provided on a written document (such as an air waybill) or on the package;(c) classification must be in accordance with provision 2;6.3.2 of the ICAO Technical Instructions;(d) the incident reporting requirements in provision 7;4.4 of the ICAO Technical Instructions must be met (these refer to operators);(e) the inspection for damage or leakage requirements in provisions 7;3.1.3 and 7;3.1.4 of the ICAO Technical Instructions (these refer to operators);(f) passengers and crew members are prohibited from transporting infectious substances either as, or in, carry-on baggage or checked baggage or on their person.
<p>(12) Clear instructions on filling and closing such packages shall be provided by packaging manufacturers and subsequent distributors to the consignor or to the person who prepares the package (e.g. patient) to enable the package to be correctly prepared for transport.</p> <p>(13) Other dangerous goods shall not be packed in the same packaging as Division 6.2 infectious substances unless they are necessary for maintaining the viability, stabilizing or preventing degradation or neutralizing the hazards of the infectious substances. A quantity of 30 ml or less of dangerous goods included in Classes 3 (flammable liquids), 8 (corrosives) or 9 (miscellaneous dangerous substances and articles, including environmentally hazardous substances) may be packed in each primary receptacle containing infectious substances. When these small quantities of dangerous goods are packed with infectious substances in accordance with this packing instruction no other requirements in these Instructions need be met.</p>	
<p>Additional requirement: Alternative packagings for the transport of animal material may be authorized by the competent authority in accordance with the provisions of 4.1.3.7.</p>	

Annex 5

❖ List of dangerous goods related to the transport of infectious substances

Proper Shipping Name	UN No.	Class or Div	Sub Risk	Hazard Labels	State Var	SP	UN Pkg Grp	Passenger and cargo aircraft				Cargo aircraft only			
								Limited quantity							
								Pkg Inst	Max net Qty/ Pkg	Pkg Inst	Max net Qty/ Pkg	Pkg Inst	Max net Qty/ Pkg	Pkg Inst	Max net Qty/ Pkg
1	2	3	4	5	6	7	8	9	10	11	12	13	14		
Aviation regulated liquid, n.o.s.	3334	9		Misc.		A27		Y964	30 kg G	964	450 L	964	450 L		
Biological substance, Category B	3373	6.2		None	GB 5					see 650		see 650			
(Bio) medical waste	3291	6.2		Inf.		A117	II			622	No limit	622	No limit		
Carbon dioxide, solid	1845	9		Misc.		A48				954	200 kg	954	200 kg		
Dry ice						A151									
Clinical waste, unspecified, n.o.s.	3291	6.2		Inf.		A117	II			622	No limit	622	No limit		
Ethanol	1170	3		Flamm Liq		A3	II	Y341	1 litre	353	5 litres	364	60 litres		
Ethanol solution						A58				355	60 litres	366	220 litres		
Ethyl alcohol						A180	III			Y344	10 litres				
Ethyl alcohol solution															
Formaldehyde solution, with not less than 25% formaldehyde	2209	8		Corrsv	US 4		III	Y841	1 litre	852	5 litres	856	60 litres		
Formaldehyde solution, flammable	1198	3	8	Flamm Liq &		A180	III	Y342	1 litre	354	5 litres	365	60 litres		
Genetically modified micro-organisms	3245	9		Misc.		A47				959	No limit	959	No limit		
Genetically modified organisms															
Infectious substance, affecting animals only	2900	6.2		Inf.	AU 3; CA 8; VU 2	A81 A140				620	50 ml or 50 g	620	4 litres or 4 kg		
Infectious substance, affecting humans	2814	6.2		Inf.	AU 3; CA 8; VU 2	A81 A140				620	50 ml or 50 g	620	4 litres or 4 kg		
Medical waste, n.o.s.	3291	6.2		Inf.		A117	II			622	No limit	622	No limit		
Methanol	1230	3	6.1	Flamm liquid		A104 A113	II	Y341	1 litre	352	1 litre	364	60 litres		
Nitrogen, refrigerated liquid	1977	2.2		Non-flamm gas		A152				202	50 kg	202	500 kg		
Regulated medical waste, n.o.s.	3291	6.2		Inf.		A117	II			622	No limit	622	No limit		

Annex 6

Special Provisions applicable to certain substances

The following Special Provisions are listed according to ICAO (*UN*):

- A3 (223) If the chemical or physical properties of a substance covered by this description are such that, when tested, it does not meet the established defining criteria for the class or division listed in column 3, or any other class or division, it is not subject to Dangerous Goods Regulations.
- A27 (276) This includes any substance which is not covered by any of the other classes but which has narcotic, noxious or other properties such that, in the event of spillage or leakage on an aircraft, extreme annoyance or discomfort could be caused to crew members so as to prevent the correct performance of assigned duties.
- A47 (219) Genetically modified micro-organisms (GMMOs) and genetically modified organisms (GMOs) packed and marked in accordance with Packing Instruction 959 are not subject to any other requirements in the Dangerous Goods Regulations.
- If GMMOs and GMOs meet the definition in 2.6 of a toxic substance or an infectious substance and meet the criteria for inclusion in Division 6.1 or 6.2, the requirements in the Dangerous Goods Regulations for transporting toxic substances or infectious substances apply.
- A48 Packaging tests are not considered necessary.
- A58 (144) An aqueous solution containing not more than 24% alcohol by volume is not subject to Dangerous Goods Regulations.
- A81 The quantity limits shown in columns 12 and 14 do not apply to body parts, organs or whole bodies.
- A104 A toxic subsidiary risk label, although not required by Dangerous Goods Regulations, may be applied.
- A113 (279) The substance is assigned to this classification or packing group based on human experience rather than the strict application of classification criteria set out in the Dangerous Goods Regulations.
- A117: Wastes transported under UN 3291 are wastes derived from the medical treatment of humans or animals or from bio-research, where there is a relatively low probability that infectious substances are present. Waste infectious substances which can be specified must be assigned to UN 2814 or UN 2900. Decontaminated wastes which previously contained infectious substances may be considered as not subject to Dangerous Goods Regulations unless the criteria of another class or division are met.
- A140 (318) For the purposes of documentation, the proper shipping name must be supplemented with the technical name. Technical names need not be shown on the package. When the infectious substances to be transported are unknown, but suspected of meeting the criteria for inclusion in category A and assignment to UN 2814 or UN 2900, the words “suspected category A infectious substance” must be shown, in parenthesis, following the proper shipping name on the transport document, but not on the outer packagings.

- A151 When dry ice is used as a refrigerant for other than dangerous goods loaded in a unit load device or other type of pallet, the quantity limits per package shown in columns 12 and 14 of the table in Annex 5 for dry ice do not apply. In such case, the unit load device or other type of pallet must be identified to the operator and must allow the venting of the carbon dioxide gas to prevent a dangerous build-up of pressure.
- A152 Insulated packagings conforming to the requirements of Packing Instruction 202 containing refrigerated liquid nitrogen fully absorbed in a porous material are not subject to Dangerous Goods Regulations provided the design of the insulated packaging would not allow the build-up of pressure within the container and would not permit the release of any refrigerated liquid nitrogen irrespective of the orientation of the insulated packaging and any outer packaging or overpack used is closed in a way that will not allow the build-up of pressure within that packaging or overpack. When used to contain substances not subject to Dangerous Goods Regulations, the words “Not Restricted” and the special provision number A152 must be provided on the air waybill when an air waybill is issued.
- A180 Non-infectious specimens, such as specimens of mammals, birds, amphibians, reptiles, fish, insects and other invertebrates containing small quantities of UN 1170 (Ethanol), UN 1198 (Formaldehyde solution, flammable), UN 1987 (Alcohols, n.o.s.) or UN 1219 (Isopropanol) are not subject to Dangerous Goods Regulations provided the following packing and marking requirements are met:
- a) specimens are:
 1. wrapped in paper towel and/or cheesecloth moistened with alcohol or an alcohol solution and then placed in a plastic bag that is heat-sealed. Any free liquid in the bag must not exceed 30 ml; or
 2. placed in vials or other rigid containers with no more than 30 ml of alcohol or an alcohol solution;
 - b) the prepared specimens are then placed in a plastic bag that is then heat-sealed;
 - c) the bagged specimens are then placed inside another plastic bag with absorbent material then heat-sealed;
 - d) the finished bag is then placed in a strong outer packaging with suitable cushioning material;
 - e) the total quantity of flammable liquid per outer packaging must not exceed 1 litre; and
 - f) the completed package is marked “scientific research specimens, not restricted. Special Provision A180 applies”.

The words “not restricted” and the special provision number A180 must be provided on the air waybill when an air waybill is issued.

Annex 7

❖ Flowchart for the classification of infectious substances and patient specimens

